

HYDRATION PRODUCTS



DRINKING FOUNTAINS and BOTTLE FILLERS

This brochure represents a portion of the extensive hydration products that Haws® offers.

Visit hawsco.com for a comprehensive list of products and accessories.



TOUCHLESS HYDRATION POWERED BY HAWS®

Haws offers various motion-activated hydration options for sanitary activation with enhanced hygienic hydration in public places.

- Maintains sleek, modern look for buildings
- Hands-free operation with a simple front motion
- Simple installation and easy-to-follow instructions for in-field installation



Model 1001HPSHO



Model 1119.14HO



Plumbing Code requirements state bottle fillers are only permitted to be substituted for drinking fountains up to 50% of the occupant load requirements for drinking fountains.* Bottle fillers enhance access to clean, hygiene drinking water for all.

* Unless the occupant load is less than 15 (International Plumbing Code) or 30 (Uniform Plumbing Code).

INTRODUCING THE ALL-NEW EWC with SENSOR ACTIVATION

- Integral anti-microbial properties
- Anti-rotational bubbler head to help prevent vandalism
- Industry-leading bottle fill rate (1.1 gpm)
- Bubbler deactivation feature for in-field changes
- Enhanced electronics to ensure filtered water at every activation (for filtered units only)
- Filter service life: 1 year or 3,000 gallons(11356L)
- 100% Lead-free waterways



- Intuitive LED display with sensor activation and easy maintenance notification and controls
- Sensor-activated drinking fountain
- Lighted bottle filler dispenser
- Stainless steel finish
- Large clearances make filter replacement and maintenance easy
- Designed with retrofit capabilities
- Smart energy saving capability is standard (filtered and bottle filler units)

QUALITY THAT DELIVERS. DESIGN THAT CAPTIVATES.

Essential to any project.

Designed with the installer in mind, the unit provides large clearances inside to allow for easy installation, filter replacement, and maintenance. All of these features make the EWC the most economical and modern choice on the market.



Model 1212SFH

Hi-lo, stainless steel, filtered electric water cooler with bottle filler with sensor-operated bottle filler and sensor-operated drinking fountains



Model 1211SFH

Single, stainless steel, filtered electric water cooler with sensor-operated bottle filler and sensor-operated drinking fountain



Model 1202SFH

Hi-lo, stainless steel, filtered electric water cooler with sensor-operated drinking fountains



Model 1201SFH

Single, stainless steel, filtered electric water cooler with sensor-operated drinking fountain

All models have filter or non-filter options

OUTDOOR BOTTLE FILLER & DRINKING FOUNTAIN

This highly-configurable product comes with fully ADA compliant standard models ideal for all outdoor installations, including school campuses, office courtyards, parks and recreational facilities.



MODEL CONFIGURATOR

Configure your own with a combination of accessories available for both sides, the back, and the top of the modular pedestal.

MODEL EXAMPLE

3 6 1 2
 # bottle fillers (0-3) # drinking fountains (0-3)

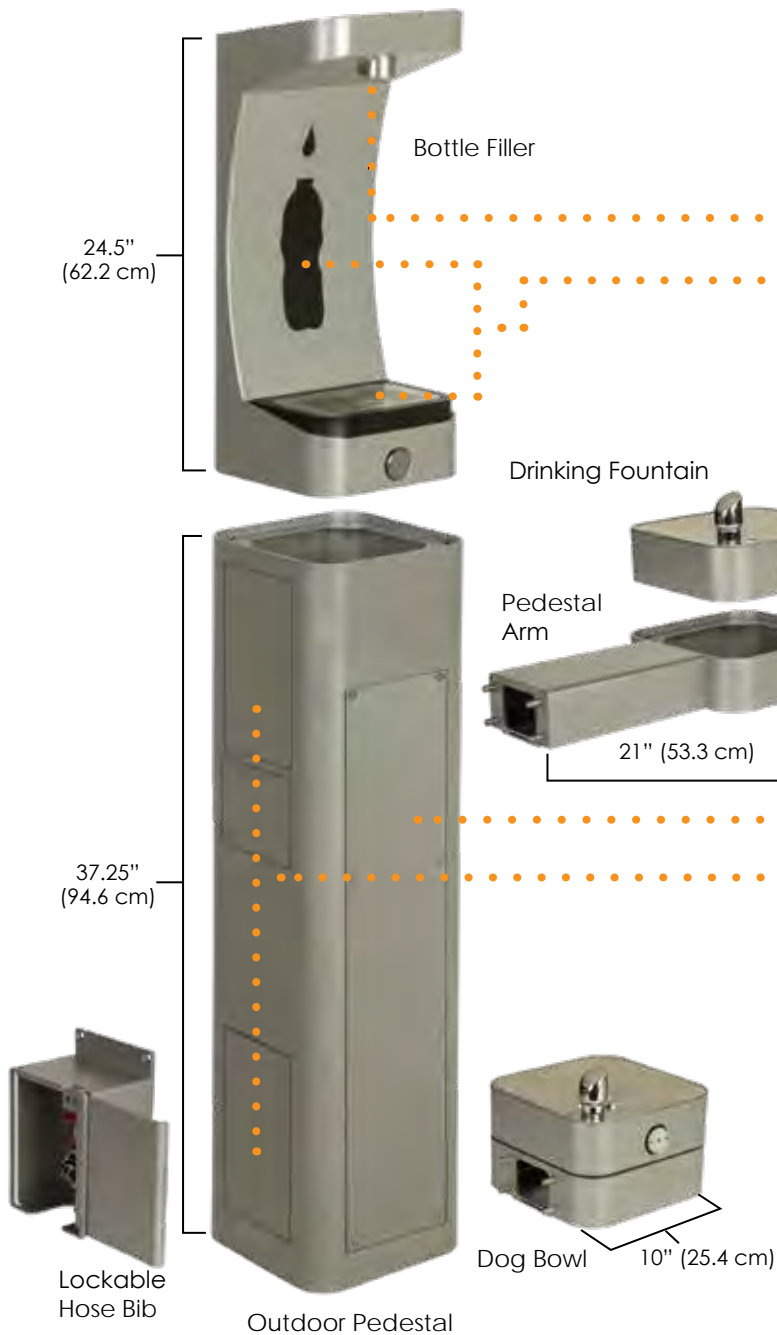

KEY FEATURES:

- Certified by CSA to NSF/ANSI 61, Section 9 and NSF/ANSI 372
- Standard models are fully ADA compliant
- Laminar, 1 GPM (3.8LPM) flow rate
- Drain pan logo and bottle color customization available
- Interchangeable accessory options
- 100% lead free waterways
- Modular arm design for pre- and in-field placement and variations
- Base pedestal is equipped with four hydration placement options and three lower accessory options
- Easy installation with convenient access to internal plumbing
- Top-down drain access for easy cleaning and maintenance
- Stainless steel with silver matte powder-coated exterior for an aesthetically appealing look that will withstand the elements
- Freeze-resistant (FR) options to maintain functionality in cold weather environments
- Unlimited custom color options
- Competitive pricing with multiple configuration options
- Environmentally-friendly hydration solution for reduced plastic consumption

STANDARD COLOR



For custom colors, contact customer service: customerservice@hawsco.com, or call 888.640.4297.



FEATURES & BENEFITS

- Touchless operation
- 100% lead-free waterways
- 18-gauge, Type 304 stainless steel bowl with 14-gauge bracket
- Polished, chrome-plated brass vandal-resistant bubbler and push button
- Satin stainless steel, and high-polished stainless steel finishes available
- Custom finishes and configurations available
- Laminar flow which produces a more even flow and eliminates splashing
- Barrier free for ADA access
- Front access stream adjustment, cartridge and strainer
- Elegant swirl bowl design channels water to ensure proper drainage
- Vandal-resistant components and bottom plates
- 100% U.S.A. factory pressure tested to meet the highest quality standards



Model 1011HPSHO

Hi-lo fountain with one sensor-operated button and one push button allowing for a touchless option. Barrier-free, high-polished stainless steel fountain with round sculpted bowls. Model 1011HPSHO2 provides two sensor-operated buttons.

WALL MOUNTED :: ARCHITECTURAL



Model 1001HPSHO

Sensor-operated, barrier-free, high-polished stainless steel drinking fountain with sculpted bowl and 100% lead-free waterways.



Model 1001HPS

Barrier-free, high-polished stainless steel drinking fountain with sculpted bowl and 100% lead-free waterways.



Model 1001MS

Barrier-free, satin finish, stainless steel drinking fountain with sculpted bowl, back panel and in-the-wall mounting system, and 100% lead-free waterways. Sensor-operated model available, 1001MSHO.



Model H1001.8HPSHO

Sensor-operated fountain for touchless hydration. High-polished stainless steel model provides 8 GPH (30.28 LPH) chilled water. Push button model available, H1001.8HPS.



Model H1011.8HO2

Sensor-operated hi-lo fountain for touchless hydration. Stainless steel with satin finish, unit provides 8 GPH (30.28 LPH) of chilled water. Model H1011.8HO also available with one sensor-operated button and one push button.

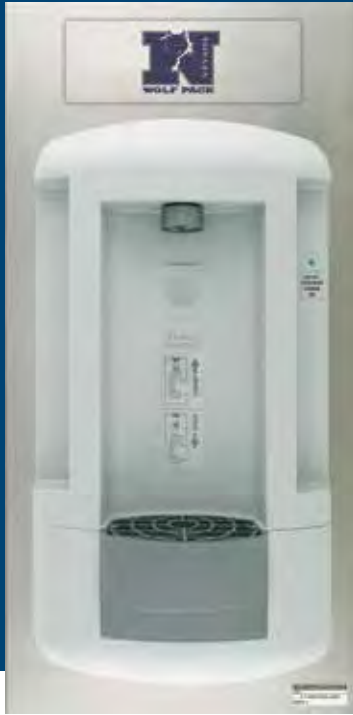

Model 2000S

Recessed (shown)

- Recessed Into Wall
- Plumbed Drain
- Purge Feature
- ADA Accessible*
- 15" W x 3.9" D x 30.25" H

Also available:

Model 2000SMS

Surface Mount

- Surface Mounted On Wall
- Integral Drain Pan with Plumbed Drain Option
- Purge Option
- ADA Accessible*
- 15" W x 6.9" D x 30.25" H

Customize your new or existing drinking fountain or bottle filler with your logo, slogan, or graphic! Increase brand recognition by personalizing your hydration products by easily retrofitting with a custom back panel, **Model 6475**.



**when mounted at correct height*



FEATURES & BENEFITS

- 100% lead-free waterways
- Polished, chrome-plated brass bubbler, push button and waste strainer
- Barrier free
- Front access stream adjustment, cartridge and strainer
- Vandal-resistant components
- Integral waste trap
- 100% U.S.A. factory pressure tested to meet the highest quality standards

Model H1117.8

14-gauge, adjustable barrier-free, hi-lo electric water cooler with adult and child ADA capabilities. Model shown with two custom panels Model 6475, and bottle filler Model 1920. Sensor-operated model H1117.8HO available.

WALL MOUNTED



Models 1920 and 1920HO

Push button and sensor-operated models available for the versatile, wall-mounted, satin finished bottle filler that can be mounted alone or above a drinking fountain. Constructed of 14-gauge, Type 304 satin finish stainless steel with 100% lead-free waterways and 1 GPM (3.78 LPM) laminar flow with stainless steel valve.



MODEL 1920 SHOWN ON DRINKING FOUNTAIN MODEL 1001 WITH BACK PLATE MODELS BP6 AND BP15

Model 1900

Bottle filler is easily mounted over virtually any drinking fountain or water cooler. Stainless steel, push-button activated valve assembly allows for front access stream adjustment as well as cartridge and strainer access. Patent pending flexible design allows for outward drain to be reversed inward allowing drain water to be connected to waste inside of wall.



Model H1119.8HO

Sensor and push button operated, hi-lo electric water cooler provides 8 GPH (30.28 LPH) chilled water. Made of stainless steel, features include vandal-resistant bubbler heads, waste strainers and bottom plates. Grille slots are designed to eliminate sharp edges and are backed with a foam filter to protect the fan motor and high displacement compressor from debris.
Dual sensor-operated Model: H1119.8HO2
Dual push button operated Model: H1119.8



MODEL H1119.8HO SHOWN WITH BOTTLE FILLER MODEL 1920, BACK PLATE MODEL BP32, AND DRIP TRAY MODEL 6469



FEATURES & BENEFITS

- 100% lead-free waterways
- Polished, chrome-plated brass bubbler, push button and waste strainer
- Barrier free
- Front access stream adjustment, cartridge and strainer
- Vandal-resistant components and bottom plates
- Integral waste trap
- 100% U.S.A. factory pressure tested to meet the highest quality standards



Model 1047

Wall-mounted design with child ADA capabilities. Heavy-duty, steel-reinforced construction with pre-cast, air-entrained concrete to ensure 5000+ PSI compressive strength. Hood extension protects the bubbler head with a partial enclosure for a greater protected drinking point. Exposed aggregate finish.

WALL MOUNTED :: OUTDOOR



Model 1025

Barrier-free, heavy-duty 11-gauge fabricated galvanized steel, with green powder-coated finish. Top-down drain access allows for cleaning without taking unit apart. Welded heavy-duty bubbler guard protects the drinking point from misuse. AVAILABLE IN CUSTOM COLORS



Model 1431

Two-bubbler, enameled iron, barrier-free fountain provides for bullet-proof durability. Bubbler heads locked to main bowl prevent against vandals and provide efficient water flow for twice the users as single-bubbler fountains.

Model 1501

Barrier-free, hi-lo, wall-mounted design with white enameled iron construction. Soft rounded corners prevent mishaps and other accidents that may occur once installed. Matching back panel provides a better base for a sturdier fountain.



Model 1409

Multi-bubbler, barrier-free, white powder-coated cast aluminum construction. Gloss finish resists stains keeping the fountain protected. Three bubbler heads locked to main bowl prevent against vandals and provide efficient water flow in high traffic areas.





FEATURES & BENEFITS

- 100% lead-free waterways
- Barrier free
- Front access stream adjustment, cartridge and strainer
- Vandal-resistant components
- Chrome-plated brass bubbler, push button and waste strainer
- Aesthetically pleasing and protective powder-coated surfaces



Models **3377 and 3377BF**

Barrier-free, 14-gauge stainless steel fountain with a satin finish stainless steel bowl and bracket, and galvanized steel green powder-coated finish pedestal. Other powder-coat colors available. Freeze-resistant model available, Model 3377FR. Galvanized steel model, 3377G. Bib faucet option available.

Shown with Model **3377BF**, bottle filler attachment, a powder-coated, 14-gauge galvanized steel pedestal extension with a satin finish stainless steel bracket.



Model **3500D**

Heavy-duty, 12-gauge stainless steel construction. Hi-lo, barrier-free design and ground level dog fountain. Green powder-coat paint finish is standard with nine other powder-coat colors available. Freeze-resistant model (without dog bowl) available, Model 3500FR.

Model **3610**

Outdoor pedestal drinking fountain is standard with a single drinking fountain station and the option of adding/changing a drinking fountain, bottle filler, dog bowl and/or hose bib at any time. Constructed of stainless steel with silver matte powder-coated exterior, and equipped with vandal-resistant components for long lasting durability.



PEDESTAL :: OUTDOOR



Model 3380

Heavy-duty, 11-gauge, fabricated galvanized steel with powder-coated finish provides exceptional corrosion resistance in one of our toughest made fountains. Standard color is green. Freeze-resistant model available, Model 3380FR.

Model 3511

Antique style pedestal made of heavy-duty, cast aluminum with powder-coated finish makes for one of the most stylish fountains that *Haws* produces. Standard color is black. Freeze-resistant model available, Model 3511FR. Bib faucet option available.



Model 3300

Hi-lo, barrier-free design. Ready for any environment with heavy-duty, 11-gauge construction, bubbler guards and recessed push buttons. Freeze-resistant model available, Model 3300FR. Bib faucet option available.



Model 3202

Angled barrier-free, trough-style design allows the pedestal to be placed securely in multiple locations where a gravel fill is present or can be installed. Gravel fill and trough design completely eliminate the need for traditional drains that can be clogged with sand and other contaminants. Bib faucet option available.

Custom Color Selections

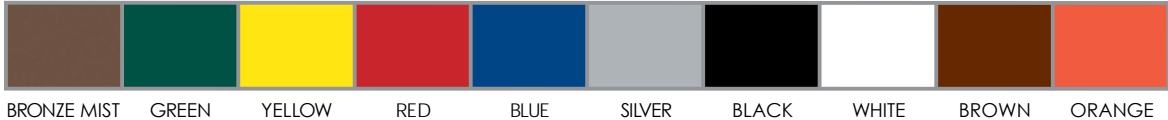



FEATURES & BENEFITS

- Heavy-duty, steel-reinforced construction with precast, air-entrained concrete to ensure 5000+ PSI compressive strength, exposed aggregate finish
- Front access stream adjustment, cartridge and strainer
- Vandal-resistant components including recessed push buttons
- Polished, chrome-plated brass bubbler, push button and waste strainer
- Oversize access panels for ease of maintenance
- Attractive, high-polished stainless steel basins
- Top-down access to the drain allows the fountain to be cleaned without taking the unit apart
- Freeze-resistant options



Model **3150**

Adjustable design allows the arm to be mounted at adult or child height as required by ADA. Hood extension protects the bubbler head with a partial enclosure for a greater protected drinking point.

CONCRETE PEDESTAL :: OUTDOOR

Model 3121

Square concrete design with exposed aggregate finish. Hood extension protects the bubbler head for a greater protected drinking point.



Model 3177

Angled barrier-free design with hood extension that protects the bubbler head with a partial enclosure for a greater protected drinking point.



Model 6620

Square concrete step that matches the color and finish of *Haws'* concrete drinking fountains to allow children access to the drinking water stream. Steel-reinforced, pre-cast construction with air-entrained concrete to ensure 5000+ PSI compressive strength with exposed aggregate finish. 10" (25.4 cm) high for surface mounting. Anchor bolts supplied.



Model 6518FR

Freeze-resistant valve system. Fully-engineered pneumatic-operated valve available for all pedestal fountains. System is installed below the frost line.



Four Concrete Finishes

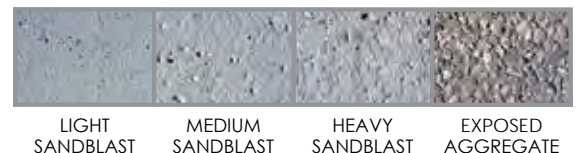

Easy to Order

- Go to www.hawsc.com
- Choose the model
- Select one of the four concrete finishes
- Select the concrete color

Sample of Concrete Colors

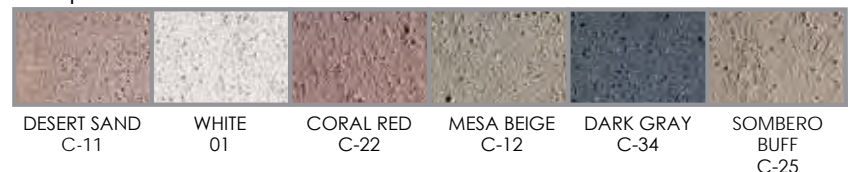

To view all concrete color options, go to www.hawsc.com

FEATURES & BENEFITS :: SINKS

- Barrier-free
- Stainless steel or enameled iron construction
- Vandal-resistant components

FEATURES & BENEFITS :: FAUCETS

- 100% lead-free waterways
- Polished, chrome-plated brass construction
- Vandal-resistant components



Model **4110ADA**

Barrier-free capabilities when mounted at appropriate height. Recessed sink design with water tight fit and stainless steel mounting rim (not shown) helps to minimize excess splashing. Heavy-duty, cast iron basin with a glossy white, acid-resisting enamel finish. Pre-punched to accept two valves and/or faucets. Model shown with optional components.



Model **4010**

Ideal for sink or counter-top locations. Push button operated with adjustable stream regulation. Equipped with mounting bracket and waste strainer. Stainless steel bowl and bubbler. Anti-squirt flow prevents surging water, keeping the drinking area contained and clean.

SINK :: COUNTER-TOP MOUNTED



Model 4230

Barrier-free, stainless steel, counter-mounted sink. Sunken sink design helps to minimize excess splashing and self-rimming feature allows for easy mounting, while the stainless steel construction provides durability and corrosion resistance. Stainless satin finish resists stains and corrosion. Water-tight fittings along with sound deadening undercarriage keep this unit mounted securely on any counter-top. Measurements: 31" x 19" x 5" (78.7 cm x 48.3 cm x 12.7 cm) deep. Model shown with optional components.

Model 5054LF

Shielded bubbler and self-closing lever handle valve with pressure regulating flow control to provide an anti-squirt drinking stream. Unit is to be mounted from a sink or counter-top and is constructed from lead-free polished chrome-plated brass, making it resistant to corrosive materials.



Model 5051LF

Shielded bubbler and self-closing lever handle valve with pressure regulating flow control to provide an anti-squirt drinking stream. Unit is to be mounted from a sink or counter-top and is constructed from lead-free polished chrome-plated brass, making it resistant to corrosive materials. Unit has vandal-resistant pins to prevent the unit from turning.



Model 5452LF

Gooseneck faucet is designed with a .5 GPM (1.9 LPM) aerator and self-closing lever handle action to provide a smooth flowing stream of water. Unit is to be mounted from sink or counter top and is constructed from lead-free polished chrome-plated brass, making this faucet resistant to corrosive materials.

Model 5510LF is the stay-open lever version.

ACCESSOIRES



Model 5010.6427SS
A polished stainless steel push-button bubbler valve for countertop or sink mounting.



Model 5017LF
All polished chrome-plated sink or counter-mounted drinking faucet with renewable control cartridge.



Model 5051LF
Polished chrome-plated lever handle bubbler valve.



Model 5054LF
Self-closing lever handle, polished chrome-plated brass deck-mounted drinking faucet with automatic stream regulation.



Model 5452LF
Self-closing lever handle, polished chrome-plated brass gooseneck faucet.



Model 5510LF
Stay-open lever handle, polished chrome-plated brass gooseneck faucet.



Model 5551
Push lever operated, self-closing, polished chrome-plated brass, deck-mounted, gooseneck cold water glass-filler faucet.



Model 5874PB
Lead-free, stainless steel, push-activated, chrome-plated brass push button valve. Includes PBA7 recessed-style, push button assembly.



Model 5874PBF
Flush-mount, lead-free, stainless steel, push-activated, chrome-plated brass, push button valve. Includes PBA6 flush-mount, push button assembly.



Model 6250LF
Self-closing, plain end, lead-free, brass bib faucet with polished chrome-plated finish.



Model 6252EHLF
Self-closing, plain end, bib faucet with rough brass finish and a special extended lever handle which is locked to valve.



Model 6423
Replacement filter for wall-mounted bottle filler, and sensor-operated bottle filling station. (U.S. and Canada only)



Model 6426
Filter, 12" x 2" (30.5 cm x 5 cm), in-line lead removal element that reduces lead from incoming water supply.



Model 6455
Polished chrome-plated brass flat waste strainer.



Model 6469
Drip tray used with the 1920 series bottle fillers for single or dual fountain.

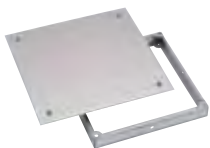

Model 6603
Satin finish stainless steel access panel. Includes frame and screws.



Model 6611
Sand trap for installing adjacent to pedestal drinking fountains to help prevent debris and contaminants from clogging waste line. Use Model 6635 for Models 3500 and 3511.



Model 6620
Matching square air-entrained concrete step for square concrete pedestals, 10" (25.4 cm) high.



Model 6700
Universal mounting plate for most single bubbler wall-mounted fountains. Panel is 18" W x 7" H (45.7 x 17.8 cm).



Model 6700.4
Hi-Lo universal mounting plate for most dual bubbler wall-mounted fountains. Panel is 36" W x 12" H (91 x 30.5 x).

ACCESSOIRES



Model 6700.4L

Mounting plate used with the 1920 series bottle fillers for dual fountain. Panel is 36" W x 7" H (91.4 x 17.8 cm).



Model 6700R

Mounting plate used with the 1920 series bottle fillers for single or dual fountain retrofit installations. Panel is 14" W x 7" H (35.6 x 17.8 cm).



Model 6715

In-wall mounting plate provides the maximum support and facilitates the installation of Hi-lo, barrier-free, 1501 series fountains. Panel is 36" W x 14" H (91 x 35.6 cm).



Model 6800

Universal in-wall mounting support for use with most fountains.



Model HCR8

Chiller provides for instantaneous cooling to meet a continuous demand for chilled water.



Model BP6

Back panel that increases location visibility. Model BP6 is 15" x 9" (38 cm x 22.9 cm) stainless steel with a satin finish. Used on model 1001.



Model BP15

Satin-finish stainless steel 15-inch back panel for Model 1920. Back panel is 15" x 17" (38 x 43.2 cm). BP15 and 1920 can be used with 1001 and 1107L models. Available in high-polished stainless steel, Model BP15HPS.



Model BP32

Satin-finish stainless steel 32-inch back panel for Model 1920. Back panel is 32" x 9.5" (81 x 24 cm). BP32 is to be used with model 1920 and 1011, H1011.8, H1117.8 or 1117L. Available in high-polished stainless steel, Model BP32HPS. Model BP32R has opening on upper left side, no high-polish available.



Model MTGFR.LG

In-wall mounting frame provides the maximum support and facilitates the installation of Hi-lo, electric water coolers.



Model MTGFR.DF2

In-wall mounting frame provides maximum support and facilitates the installation of 1011MS and 1011HPSMS series fountains.



Model MTG.3501

Galvanized steel anchors.



Model SK1

Satin finish stainless steel cane touch skirt for high unit to comply with ADA protruding objects guidelines.



Model SK3

Satin finish stainless steel cane touch skirt for high unit to comply with ADA protruding objects guidelines when needed.

5874PBF :: PUSH BUTTON ACTIVATION VALVE

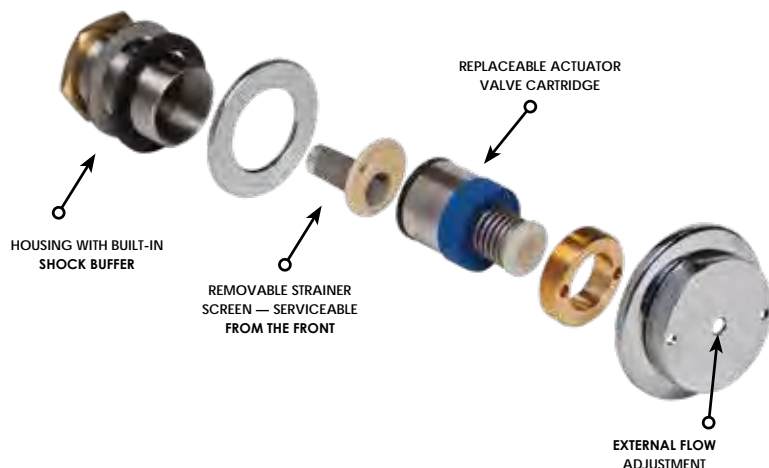

All components meet NSF61

The stainless steel valve with chrome-plated push button is lead-free and includes various operation and maintenance functions:

- Integral buffer mechanism that cushions the effects of sudden pressure changes
- Front access for flow height adjustments, cleaning, and cartridge replacement
- Integrated quick connects and mechanically crimped for easier installation, less leak paths and overall extended life.
- Sediment screen built into the valve housing

Model 5874PBF is on all non-freeze-resistant *Haws* drinking fountains and can be retrofitted into existing non freeze-resistant drinking fountains.

Model 5874PB is the recessed version.

CERTIFICATIONS

AB1953

AB1953 is encompassed in the California Assembly Bill 1953, enacted in September of 2006, which calls for a reduction in lead content in all plumbing equipment including pipes, fittings, and fixtures to a level less than 0.25%. This law went into effect on the first day of January 2010 and all the aforementioned products sold and installed on and after that date must meet this AB1953 lead reduction requirement. In 1990, Haws was already manufacturing products that fall within the lead reduction requirement that is now in effect.

All Haws drinking fountain products are lead-free, AB1953 compliant, and have NSF/ANSI 61-section 8 or section 9 and NSF/ANSI 372 certifications, obtained through the internationally recognized CSA Testing Laboratory.

CERTIFICATIONS

The CSA and UL certification marks signify that the product meets applicable U.S. and Canadian standards, including those from CSA, ANSI, ASME, ASSE, ASTM, IAPMO, NSF, and UL.

Below is a list of certifications that Haws' drinking fountain models and optional accessories have been tested and certified to use. Certifications for each model can be found in the model descriptions at www.hawesco.com.

CSA: Canadian Standard Association International



FCC/IC: Electronic Product
FCC (U.S.), IC (Canada)

FCC/IC

UL: Underwriters
Laboratories



Wheel Chair Accessible products

SHARP STATUS

In 2018, Haws was awarded SHARP status (Safety and Health Achievement Recognition Program) by the Nevada Division of Industrial Relations.



MASTERSPEC®, REVIT, CAD

Masterspec® files now available for Haws products, as well as revit and cad files from caddetails and bim object.



LEAD-FREE PRODUCTS SINCE 1990



Reduction of Lead in Drinking Water Act, an amendment to the *Safe Drinking Water Act*, establishes a maximum lead content of wetted surfaces of plumbing products to a weighted average of 0.25%. With an effective date of January 4, 2014, this law necessitates all potable plumbing products sold and installed meet the new lead reduction requirement.

All *Haws* drinking fountain products are lead-free, as well as several *AXION*® Emergency Tempering Valves. These *Haws* products have NSF/ANSI 61-section 8 or section 9 and NSF/ANSI 372 certifications, obtained through the internationally recognized CSA Testing Laboratory, and are AB1953 compliant.

WHAT PRODUCTS ARE INCLUDED?

Pipes, pipe fittings, plumbing fittings and fixtures that may provide water for human consumption. This includes devices that are typically integrated into a faucet or plumbing system that deliver drinking water.

HOW DOES THE LAW APPLY TO REPAIRS AND REPLACEMENT PARTS?

Pipes, fittings or fixtures that were installed prior to the effective date and are being repaired do not need to meet the new definition of lead-free because the pieces are not being "introduced into commerce" but any replacement parts must be the lead-free definition.

Information sourced from water.epa.gov/drink/info/lead

SCHOOL PRODUCTS



Model **7620**
AXION® eyePOD®



Model **5051LF**
Shielded bubbler
for deck-mount sink



Model **3612**
Outdoor Bottle
Filler and Drinking
Fountain

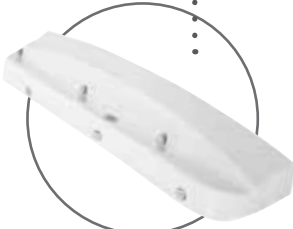

Model **1409**
Wall-Mounted
Drinking Fountain



Model **1212S**
Hi-lo filtered electric
water cooler with
bottle filler

BOTTLE FILLER FUNDRAISING PROGRAM

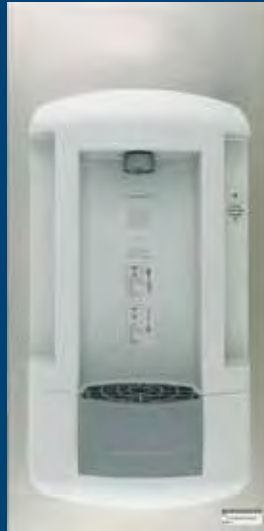

Model 2000S
Recessed Mount



Model 2000SMS
Surface Mount

The *Haws* bottle filling stations offer a convenient, healthy hydration option. The units easily mount to most wall surfaces and dispense clean, filtered water from standard tap lines.

Purchase reusable bottles customized with your logo to pay for your bottle filling station!

The Fundraising Program allows your school or non-profit to easily raise the funds needed to purchase your own bottle filling station.

Fundraising Program Process

- SIGN-UP and receive 300 customized Nalgene® bottles with your logo
- SELL your customized bottles
- PAY for the program with the bottle sales proceeds

Bottle Filling Station Features:

- Clean Filtered Water supplied by a Certified Advanced Filtration System
- Touch-Free, Hygienic Water Dispenser
- Filter Replacement Indicator Light
- Durable 16-Gauge Stainless Steel
- 30-Second Water Time-out

How To Apply

Call 888.909.4297 or to fill-out the online form, go to <https://www.hawesco.com/hydration/bottle-filler-fundraising-program>

CORE PURPOSE TO IMPROVE THE HEALTH & SAFETY OF OUR GLOBAL COMMUNITY.



GLOBAL CUSTOMERS



GLOBAL VISION



LOCAL SERVICE

Ingenuity is the *Haws* culture. Every day we work to address your needs and solve your challenges by applying imagination and initiative to make your job easier. *Haws* is committed to improving the health and safety of our global community by providing customer focused hydration, safety, and tempering solutions. With more than 8,000 distribution locations and 250 employees worldwide, we continually focus on quality, service, reliability and complete solution support.

With the invention of the drinking fountain in 1906 by Luther Haws, the Haws Sanitary Drinking Faucet Company formed in 1909 in Berkeley, California. During the 1950s, *Haws* introduced emergency drench showers and safety eyewashes into its manufacturing line. Establishing headquarters in Sparks, Nevada in 1996, *Haws* continued expanding, opening various global locations. In 2018, the Nevada Division of Industrial Relations awarded SHARP status (Safety and Health Achievement Recognition Program) to *Haws*.

To this day, *Haws'* innovative spirit is driven by third, fourth and fifth generations of the *Haws* family.



DON'T SEE EXACTLY WHAT YOU'RE LOOKING FOR?

Our team can help create a personalized product solution to fit your needs.

Below are some commonly ordered custom designs:

- Custom colors
- Modified product dimensions
- Custom logos

Call us at **888.640.4297**, or email info@hawsco.com

US/Canada

Haws HQ • www.hawsco.com • +1.888.640.4297

Mexico/Central America

Haws HQ • www.hawsco.com • +1.775.359.4712

South America

Haws Avlis • www.hawsavlis.com.br • +55.11.4813.9977

Asia Pacific

Haws Singapore • www.haws.sg • +65.6367.0359

Haws India • www.hawsco.in • +91.124.494.2050

Haws Korea • www.hawsco.kr • +65.6586.9198

Europe/Middle East/Africa

Haws Switzerland • www.haws.ch • +41 (0) 34.420.6000

Haws Germany • www.hawsgmbh.de • +49 (0) 2405.21055

